

段差机用砂轮 Superabrasive Wheels for Peel Grinding

主要特点

磨削效率高，耐用度好；

优越的尖角保持性；

加工工件尺寸一致性好。

Main features

High grinding efficiency and durability.

Good shape holding capacity.

Good consistency of workpiece dimension.

适用加工材料

主要用于硬质合金、高速钢、不锈钢等棒料的段差磨削。

Application

Mainly used for peel grinding of tungsten carbide, high speed steel and stainless steel.

形状代号及简图 Models and profile sketches

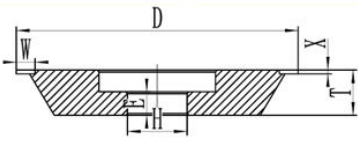
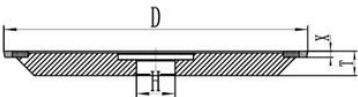
形状代号Model	剖面简图Profile Sketches	常用规格Universally Specs	
3A1		3A1	$D \times T \times H \times X \times U$
		D	75-350
		X	3-10
		U	2-10
3B1Z		3B1Z	$D \times T \times H \times W \times X$
		D	75-350
		X	3-10
		U	2-10